

Oil Skimmers

ENVICARE'S Industrial ranges of Oil skimmer is the equipment that removes floating oil from the surface of a fluid. In general, oil skimmers work because they are made of oilophilic property, which means that belt attracts the oil more than the liquid on which it's floating. It's available in different standard sizes and as per the need of the client. The standard widths of the belts are 50 mm, 100mm, 150mm, 200mm and 250 mm. Oil skimming capacity ranges from 5 Lit/hr to 25 Lit/hr.



Features :

- Less operating cost
- Less maintenance cost
- Suitable for any liquid
- Robust, compact, and re-locatable
- Can be integrated with existing systems without much modifications

Salient Features :

- Most inexpensive way to remove oil from water
- Saves coolants by removing tramp oil
- Conserves parts wash water by removing oily wastes
- Prevents plugging of spray heads and filters
- Reduces fluid disposal costs
- Skimmed oil can be recycled and reused as a lubricant or fuel

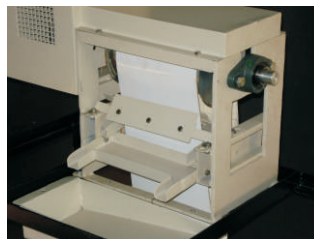
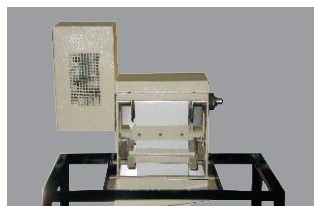

Application:

- Petroleum refineries, lube blending plants
- Oil drilling services
- Mineral and vegetable oil plants
- Automobile units and service stations
- General engineering industries and machining centre
- Industries employing industrial washing machines
- Perfumery and essential oil industries
- Effluent treatment plants and sewage treatment plants

Types :

There are mainly two types

- 1) Belt type
- 2) Disc type

We mostly manufacture belt type oil skimmers which utilizes UP belt.

This belt is lowered into the liquid that needs to be cleaned. The belt then passes through special wiper blades, which remove the oil from both sides of the liquid as it passes through. Disc oil skimmers use a disk that is rotated through the liquid. The oil is wiped off the liquid and placed into a special collection container within the skimmer.

OIL SKIMMER MODEL- ETPL-OSB-150/3000

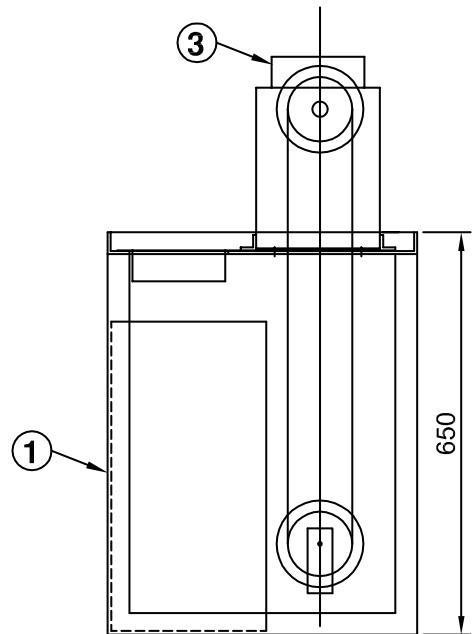
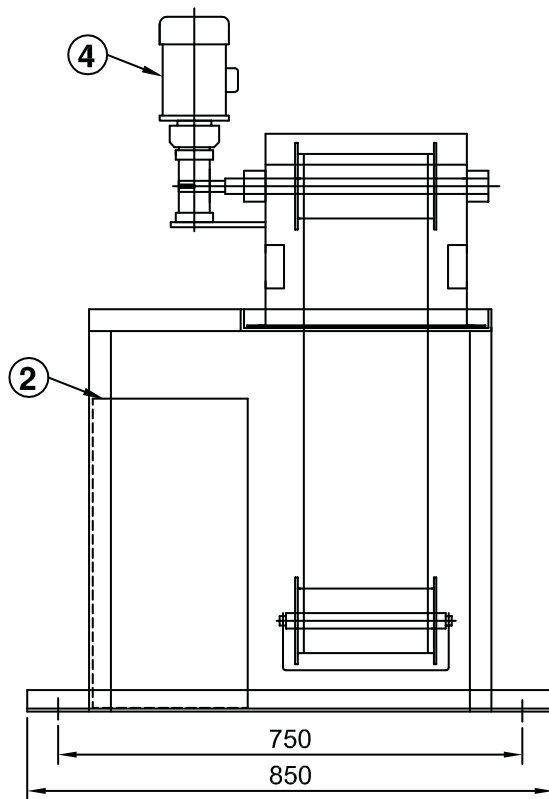
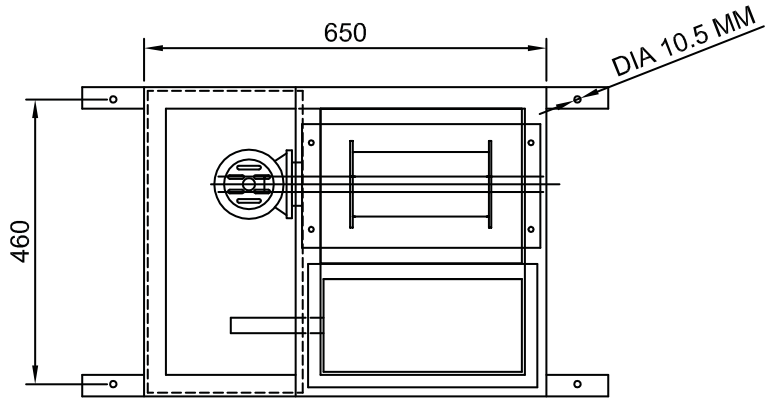

GA FOR OIL SKIMMER & STAND
FOR 15 LPH

4	DRIVE	BONFIGLOLY/VARVEL	1		
3	OIL SKIMMER UNIT	ENVICARE	1		15 LPH
2	COLLECTION TANK	ENVICARE	1		50 LITS
1	SKIMMER STAND	ENVICARE	1		
NO.	MATL.DESCRPTION	MAKE	QTY.	WT./PC.	REMARKS